

Gulliver R10

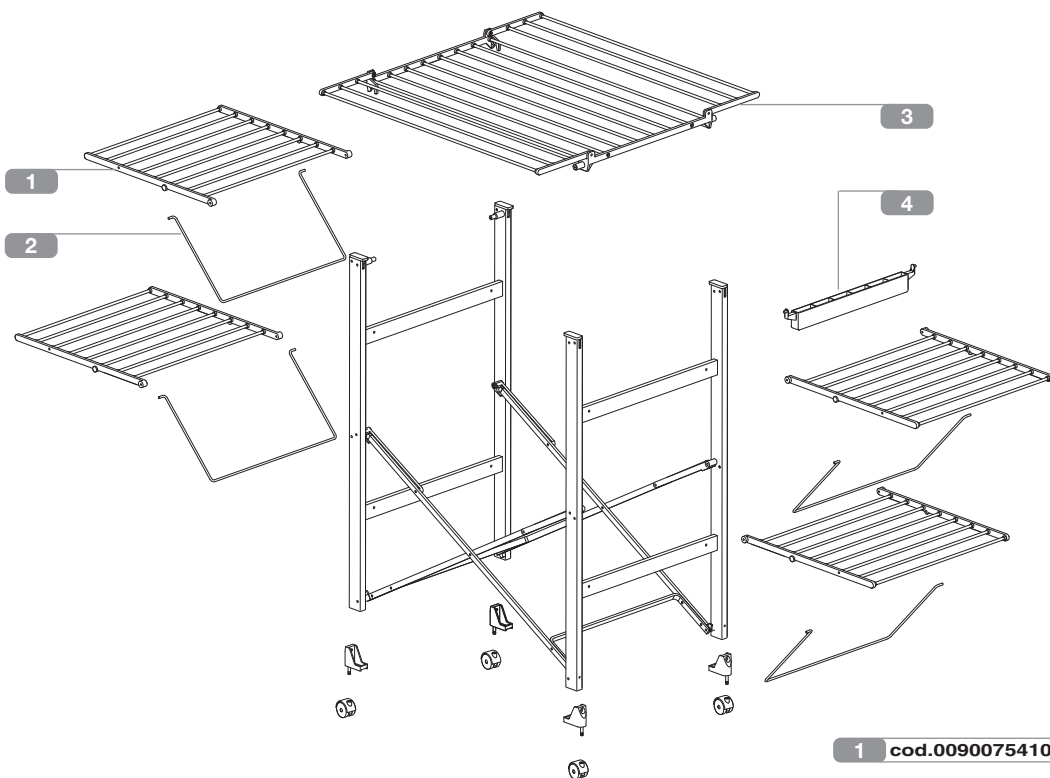

1 cod.0090075410

2 cod.7030415880

3 cod.0090075310

4 cod.0047270110

5A cod.0040102519

5B cod.0040101119

6 cod.0049220219

7 cod.0049220419

8 cod.0040003110

9 cod.0047270210

10A cod.0090126119

10B cod.0090075219

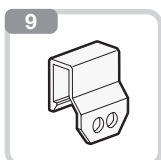
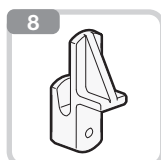
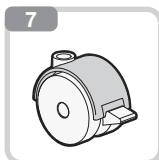
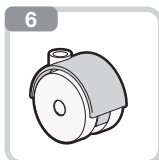

I Ogni codice ricambio deve essere sempre composto da dieci cifre: completare gli eventuali codici da otto cifre con le due indicanti il colore.

Attenzione: le sostituzioni devono essere richieste solamente tramite il rivenditore.

GB The codes for spare parts must be made up of ten figures: complete the eight figure colour code with the two figure colour code.

Note: spare parts can only be ordered from the retailer.

F Chaque code je rends doit être toujours composé de dix chiffres : compléter les eventuels codes de huit chiffres avec deux heures indiquant la couleur.

Attention: les substitutions ne peuvent être effectuées que par l'intermédiaire du revendeur.

D Jeder Code gebe ich zurück muß mich immer aus zehn Zahlen zusammensetzen: die möglichen Codes von acht Zahlen mit zwei Stunden zu vervollständigen, die die Farbe angeben.

Wichtig: ersatz darf nur über den Händler angefordert werden.

E Cada código vuelvo debo siempre ser compuesto de diez cifras: completar los posibles códigos de ocho cifras con las dos horas que indican el color.

¡Atención! las sustituciones deben ser solicitadas solamente a través del revendedor.

NL Elke code geef ik moet altijd uit tien cijfers samengesteld zijn terug: de eventuele codes van acht cijfers met twee uur aanvullen dat de kleur aangeeft.

Opgelet: vervangingen dienen uitsluitend via de wederverkoper te worden besteld.

Legno massiccio 12

Alluminio 00

Argento 36

Arancio 54

Wengè 86

Pink 38

Green 41

Bianco/rosso 90

FOPPAPEDRETTI

Foppa Pedretti S.p.A. Via A. Volta, 11
24064 - Grumello del Monte, Bergamo - Italy
tel +39 035.830.497 fax +39 035.831.283
www.foppapedretti.it



FOPPAPEDRETTI®

FOPPAPEDRETTI
l'albero delle idee

Istruzioni di montaggio e uso	Montage- und Gebrauchsanweisung
Instructions for assembly and use	Instrucciones de montaje y uso
Instructions de montage et mode d'emploi	Aanwijzingen voor de montage en het gebruik

Stendibiancheria chiudibile
Folding clothes airer
Sèche linge pliant
Zusammenklappbarer Wäscheständer
Cuelga lencería plegable
Inklapbaar handdoekenhouder



made in Italy

Gulliver

Avvertenze Warning Avvertissement Warnung Advertencias Waarschuwingen

I Leggere attentamente e conservare per future referenze

- Controllate periodicamente il perfetto bloccaggio di tutti i componenti.
- Verificate la perfetta apertura di **Gulliver** prima di appendervi la biancheria.
- Per evitare rischi di ribaltamento non stendere la biancheria sui telai laterali quando **Gulliver** è chiuso (fig. A).
- Pulire con un panno umido o del detergente neutro (**no solventi**) e asciugare accuratamente.
- Non esporre alle intemperie.

GB Read the instructions carefully and keep for future reference

- Every so often check that all the components are perfectly secure.
- Check that **Gulliver** has been opened out correctly before hanging washing on it.
- To prevent **Gulliver** from tipping over, do not hang washing on the side frames when it is folded (fig. A).
- Clean with a damp cloth or with neutral detergent (**not solvents**) and dry carefully.
- Do not leave out in bad weather.

F Lire attentivement et conserver en cas de besoin

- Contrôler périodiquement le parfait blocage de tous les composants.
- Vérifiez la bonne ouverture de **Gulliver** avant d'étendre le linge.
- Pour éviter au séchoir de se renverser n'étendez jamais le linge sur les châssis latéraux quand **Gulliver** est fermé (fig. A).
- Nettoyez à l'aide d'un chiffon humide ou de détergent neutre (**non-solvants**) puis essuyez-le soigneusement.
- Ne pas exposer aux intempéries.

D Aufmerksam lesen und für zukünftige Referenzen aufbewahren

- Regelmäßig die perfekte Befestigung aller Komponenten kontrollieren.
- Die perfekte Öffnung von **Gulliver** überprüfen, bevor Wäsche darauf aufgehängt wird.
- Um die Umkipppgefahr zu vermeiden, keine Wäsche auf die seitlichen Rahmen hängen, wenn **Gulliver** geschlossen ist (fig. A).
- Mit einem feuchtem Tuch oder neutralem Reinigungsmittel (**keine Lösungsmittel**) reinigen und gut abtrocknen.
- Keinen Witterungseinflüssen aussetzen.

E Leer atentamente y conservar para futuras referencias

- Controlar periódicamente el bloqueo perfecto de todos los componentes.
- Verificar la perfecta apertura de **Gulliver** antes de colgar la ropa.
- Para evitar riesgos de vuelco no colgar la ropa sobre los bastidores laterales cuando **Gulliver** está cerrado (fig. A).
- Limpiar con un paño húmedo o con detergente neutro (**no con solventes**) y secar cuidadosamente.
- No exponer a la intemperie.

NL Lees deze aanwijzingen met aandacht en bewaar ze voor gebruik later

- Regelmatig controleren dat alle onderdelen perfect geblokkeerd zijn.
- Controleren dat **Gulliver** op de juiste wijze is geopend alvorens het wasgoed op te hangen.
- Geen wasgoed op de zijkanten van de constructie hangen als **Gulliver** gesloten is, dit om omvallen te voorkomen (fig. A).
- Met een vochtige doek of een neutraal reinigingsmiddel (**geen oplosmiddelen**) schoonmaken en zorgvuldig droogmaken.
- Niet blootstellen aan weer en wind.

Montaggio Assembly Assemblage Montage Montaje Montage

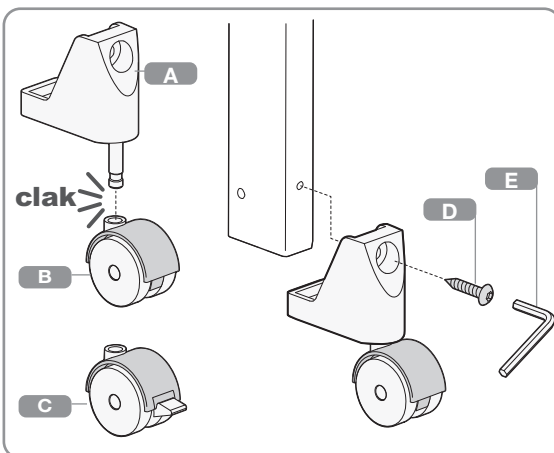
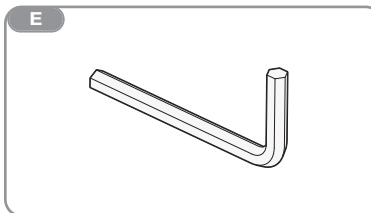
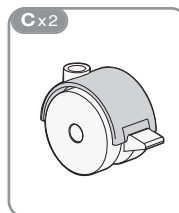
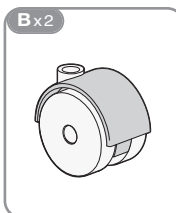

open

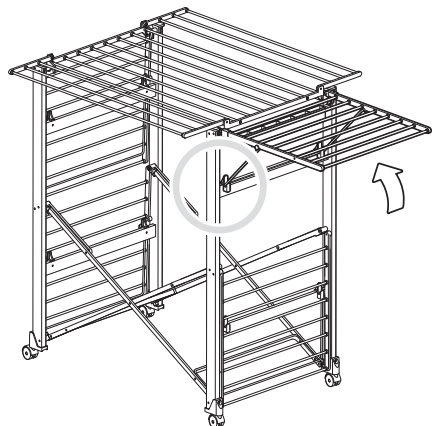
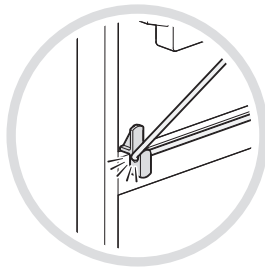
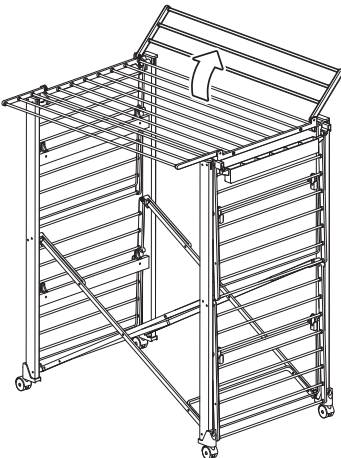
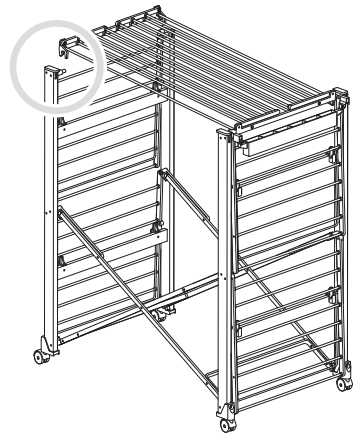
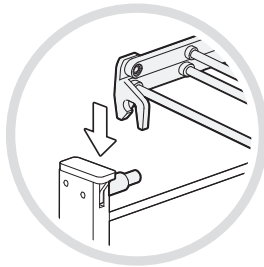
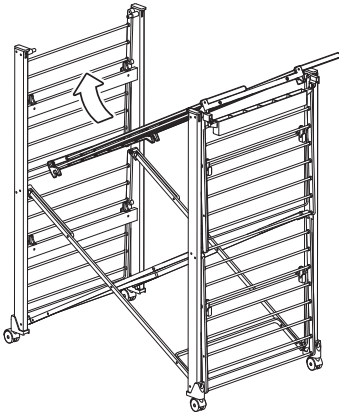
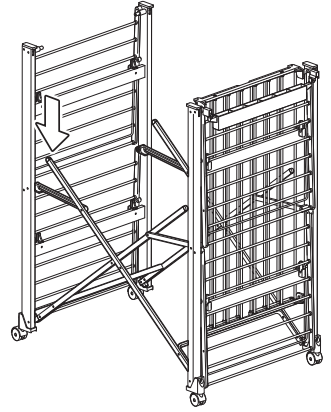
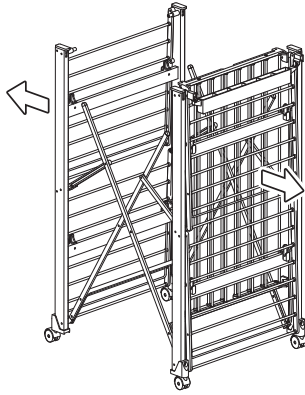
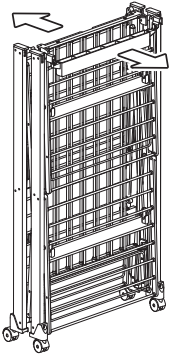

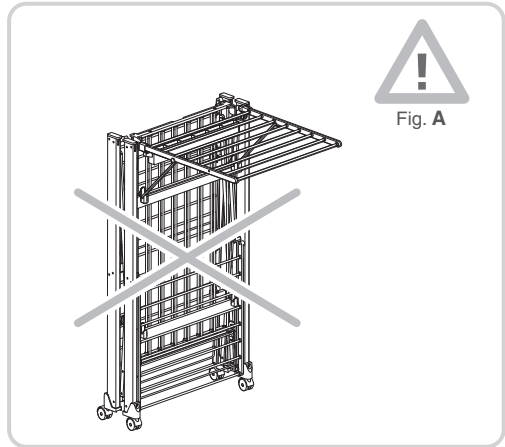
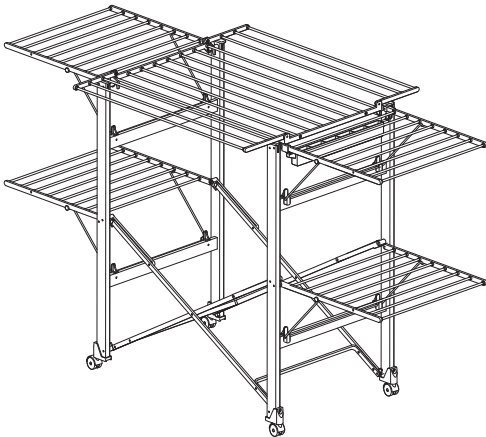

closed

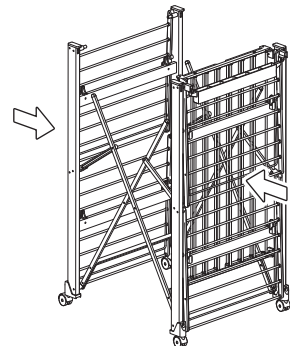
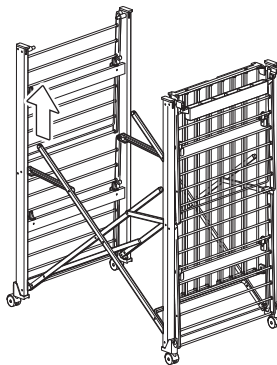
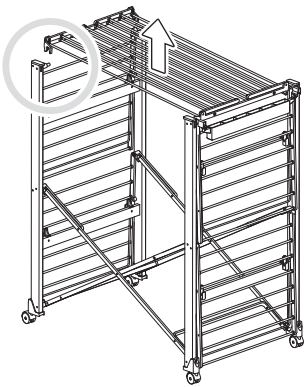

Composizione

Composition

Composition

Materialien

Composició

Materialen

- I** • Telaio di sostegno in legno di faggio per la versione legno.
- Telaio di sostegno in alluminio per le versioni alluminio.
- Bacchette stendibiancheria in alluminio verniciato.
- Tiranti di apertura/chiusura in alluminio verniciato.
- Supporti portabacchette in materiale plastico.
- Ruote in nylon.
- Vaschetta portamollette *Clothy* in materiale plastico.

- GB** • Beechwood supporting frame for the wooden version.
- Coated aluminium supporting frame for the aluminium versions.
- Coated aluminium airing rails.
- Coated aluminium opening/closing rods.
- Plastic rail supports.
- Nylon castors.
- Plastic tray for *Clothy* clothes-pegs.

- F** • Châssis support en bois de hêtre pour la version bois.
- Châssis support en aluminium pour la version aluminium.
- Tringles en aluminium vernis.
- Tirants ouverture/fermeture en aluminium vernis.
- Supports porte-tringles en matière plastique.
- Roulettes en nylon.
- Bac porte pinces *Clothy* en matière plastique.

- D** • Stützrahmen aus Buchenholz für die Version aus Holz.
- Stützrahmen aus lackiertem Aluminium für die Version aus Aluminium.
- Stäbe des Wäscheständers aus lackiertem Aluminium.
- Öffnungs-Schließungsspannstangen aus lackiertem Aluminium.
- Stangenhalterungen aus Plastikmaterial.
- Rollen aus Nylonelemente.
- Klammernhalterwännchen *Clothy* aus Plastikmaterial.

- E** • Bastidor de sostén de aluminio pintado para la versión en aluminio.
- Bastidor de sostén de madera de haya para la versión en madera.
- Varillas del tender de aluminio pintado.
- Tirantes de abertura/cerrado de aluminio pintado.
- Soportes porta varillas de material plástico.
- Ruedas de nylon.
- Cubeta porta broches *Clothy* de material plástico.

- NL** • Beukehouten draagconstructie voor de uitvoering in hout.
- Aluminium draagconstructie voor de uitvoering in aluminium.
- Drooglijnen van gelakt aluminium.
- Stangen voor openen/sluiten van gelakt aluminium.
- Drages van drooglijnen van kunststof.
- Nylon wielen.
- Wasknijpermandjo *Clothy* van kunststof.